

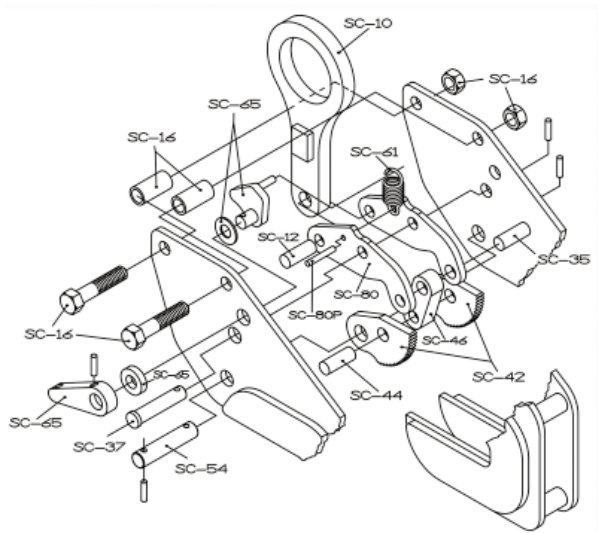

SAFETY CLAMPS, INC.
HOME OF THE "BIG BITE" LIFTING CLAMP

Operation, Maintenance and Repair Manual for **Model HBC**



Products manufactured by Safety Clamps, Inc. meet
and/or exceed ANSI/ASME B30.20 standards

Warning

**Prior to operating your Safety Clamp, please ensure
All operators read and understand this manual.**

Effective January 1, 2016

This Manual is only for Model HBC clamps manufactured after 2015.

Contact Safety Clamps, Inc. to obtain a manual for a
Model HBC clamp manufactured before 2016.

Serial # _____

Model _____

Max. Rated Capacity in Tons _____

Jaw Opening _____

Safety Clamps, Inc. Repair Service Center

- ◆ Call 1-800-456-2809 for a Return Authorization Number.
Include:
Model
Rated Capacity
Serial Number
- ◆ You will receive a written quote within 24 hours of receipt of your Safety Clamp.
- ◆ Your Safety Clamp will be repaired, tested, re-certified, painted, and shipped within 24 hours of authorization.
- ◆ We also perform periodic inspections and re-certifications.
- ◆ It's that easy! Call 1-800-456-2809 for more details.

Register Your Clamp

Go to www.safetyclamps.com to register your clamp to receive the most appropriate service and product support for your clamp and new product updates as they come available.

10 Year Limited Warranty

All products manufactured by Safety Clamps, Inc. carry a limited warranty that the product is free from defects in materials and workmanship. This warranty applies only to the original end user of the clamp and is valid for 10 years from the date of purchase.

Conditions

This warranty only covers defects in materials and workmanship and only if the clamp has been inspected, maintained, and operated within the guidelines of the clamp's Operation, Maintenance, and Repair Manual. The warranty does not cover wear to parts such as pins, grippers, lock springs, etc. If a defect is found within the warranty period, the clamp will be repaired or replaced by determination of the manufacturer.

No warranty is given due to: regular wear; incorrect use; overload; modification of the clamp; improper maintenance and/or repair.

GENERAL INFORMATION

1. The Model HBC is designed as a multipurpose clamp for lifting, positioning, and erecting structural beams and prefabricated sections. The split lower jaw also allows the operator to load the clamp on the ends of I Beams.
2. The HBC model has an over-center lifting shackle for stability when lifting structural beams from the flange and helps hold the beam in place.
3. Always choose the proper clamp and rated capacity for the material to be lifted.
4. The Model HBC maintains a 100% rated lift capacity with a forward sling angle up to 90° and a back sling angle up to 45° (Fig. 1).
5. The Model HBC has a locking handle that locks the clamp open to facilitate loading and unloading, and locks the clamp closed onto the material to be lifted for a more secure lift. Always store the clamp in the locked open position.
6. The locking handle also has a remote release design so, when needed, the operator can attach a tag line and safely lock the clamp open from a distance once the load has been securely positioned and the weight of the load is removed from the clamp.
7. The Model HBC is rated to lift material with a hardness up to 450 Brinell (48 Rockwell C) and is also available with stainless serrated grippers. For material harder than 450 Brinell, or for polished metals, use the Model HBC with smooth steel or smooth stainless non marring grippers.
8. The operator must read and understand the Operator's Manual before using a Safety Clamp.

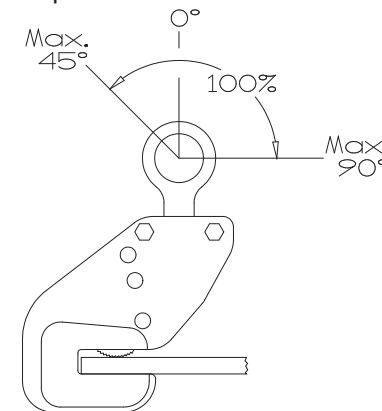

Figure 1

OPERATING AIDS

1. The Model HBC should not be used to handle material with temperatures below 0° F or above 225° F. These temperature restrictions apply to both the ambient temperature and the temperature of the material to be lifted.
2. Do not use the Model HBC for vertical movement of material.
3. Do not use clamps with serrated grippers on materials with a hardness in excess of 450 Brinell (48 Rockwell C). For material harder than 450 Brinell, or for polished metals, use the Model HBC with smooth steel or smooth stainless non marring grippers.
4. Do not lift material with mill scale, grease, or any other coatings that may prevent gripping surface from making solid contact with material.
5. Never exceed fifteen degrees (15°) side load with a Model HBC clamp (Fig. 2).
6. Never exceed a 90° frontward sling angle (Fig. 1).
7. Never exceed a 45° backward sling angle (Fig. 1).
8. Make sure the load to be lifted is properly balanced. Multiple clamps may be needed to balance the load.
9. Never lift or transfer material over or near people.
10. Always lock the clamp closed before making a lift. Don't make a lift with the lock in the open or locked open position.
11. Do not lift clamp with an open-end hook.
12. Do not alter clamp. Do not weld, grind, or modify the clamp in any way.
13. If a clamp has been overloaded or damaged in any way, take the clamp out of service immediately.
14. Do not improvise and misuse the clamp. Always use correct clamp for the lift.

OPERATION**Inspection Before and After Each Use**

The Safety Clamps inspection procedures meet and/or exceed the requirements set forth in the ASME B30.20 Below-the-Hook Lifting Devices guideline.

1. Before using any Safety Clamp, the operator must read and understand the Operator's Manual in its entirety.
2. All Safety Clamps should be inspected before and after each use. Do not use if any components are bent, elongated, gouged, nicked excessively, worn, and/or damaged. Make sure that nuts, bolts, pins, and other mechanical fasteners are tightened and secured.
3. Be sure the clamp to be used is the proper clamp for the job. Check the rated capacity and jaw opening stenciled on the Identification Tag. Both should equal or exceed the requirements for the load to be lifted.

Warning: Never exceed the rated capacity or use on material that is not within jaw range of the clamp.

4. Do not use the clamp if the Identification Tag or the Warning Tag is missing or illegible.
5. Inspect the gripping cam(s) (SC-50 or SC-42, Fig. 5) for wear and defects. Gripping surfaces must be sharp and free of foreign matter.
6. Inspect the condition of the body for wear, damage and distortion, particularly in the area of the jaw opening and holes for pins.
7. Inspect the lifting shackle (SC-10, Fig. 5) and all pins for wear and damage.
8. The lock spring (SC-61, Fig. 5) must have a definite amount of tension when the lock is moved to the Lock Closed position, with minimal material in the clamp.
9. Remove from service and tag any clamp in need of repair indicating the problem area and bring to supervisor's attention. A full periodic inspection is to be performed at this time by qualified personnel (see periodic inspection, p. 9). The next periodic inspection will be timed from when the clamp is returned to service.
10. Make sure that all roll pins are securely in place.
11. Never use a clamp in need of repair.

OPERATION

Loading the clamp

1. When placing the clamp onto the material, the clamp should be in the locked open position with the gripping cam(s) out of the jaw opening. This helps to prevent damage to the gripping teeth during loading.
2. Center the clamp so the load is balanced when lifted. When using more than one clamp, make sure the clamps are positioned to share equal loads.
3. Ensure the clamp is positioned so the direction of force applied by the crane is in line with the lifting shackle (Fig. 2).

WARNING: Never exceed 15° side loading with a Model HBC clamp (Fig. 2).

4. Place the jaw of the clamp around the material to be lifted. Make sure the clamp is positioned so the edge of the material is 1/8" to 1/4" from the back of jaw opening and the gripping surfaces are in full contact with the material.
5. Secure the clamp in the lock closed position. Do this by seating the material in the clamp jaw opening with the lower jaw against the material and rotating the lock handle (A, Fig. 4) until the lock inside the body is positioned against the stop (B, Fig. 4). The gripping cam(s) (C, Fig. 4) will rotate into the jaw and engage the material at the point where they will bite into the material once the load is applied.
6. Once the clamp is properly locked closed onto the material, the clamp is now ready to make a lift.

WARNING: The operator and all other personnel should be fully clear of the lifting area.

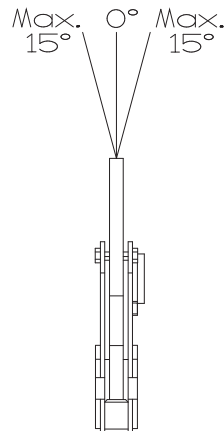

Figure 2:
Never exceed 15° side load
with a Model HBC clamp.

OPERATION

Lift and Transfer of Material

1. As the operator begins to make the lift, ensure the load is balanced. If the load is not balanced, lower the material and adjust the position of the clamp(s) accordingly and follow the guidelines under the "Loading the clamp" section. **Never** lift or transfer material when the load is not balanced.
2. During transfer of the material from one location to another, the operator should ensure the load is steady during transfer and not allow the load to bump or strike other objects.
3. Upon reaching the material's destination, lower the clamp and material to a secure position until the tension is relieved on the lifting shackle (D, Fig. 3).
4. Once the load is at rest and secured, rotate the lock handle (A, Fig. 3) to the locked open position. This will disengage the clamp from the material and lock the gripping cam(s) (C, Fig. 3) out of the jaw opening to protect the gripping teeth. If the clamp is in a hard to reach position, push in on the lifting shackle (D, Fig. 3) after the lock handle (A, Fig. 3) is released to help facilitate locking the clamp open.

Note: Always store the clamp in the locked open position to protect the grippers and help ensure longer use.

Warning

Operator must follow all guidelines in each section before making a lift.

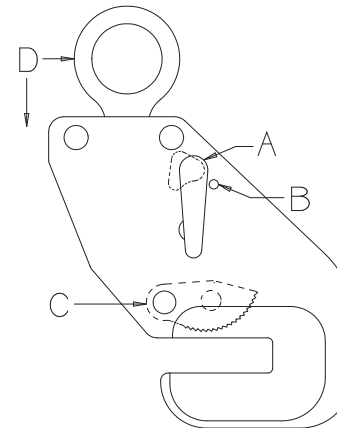

Figure 3: Locked Open

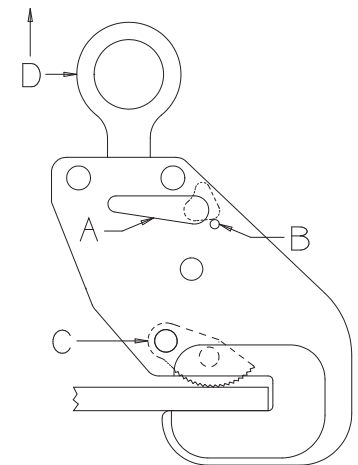

Figure 4: Locked Close

Part #	Parts List for 1 ton Model HBC
SC-10	Lifting Shackle
SC-12	Lifting Shackle Pin
SC-16	Body Bolt Assembly (1 spacer, bolt, & nut)
SC-35	Connecting Yoke-Cam Link Pin
SC-37	Connecting Yoke Body Pin with roll pin
SC-50	Gripping Cam Assembly (SC-42, SC-44, (2) SC-46)
SC-50ST	Serrated Stainless Gripping Cam Assembly
SC-50NM	Smooth Steel Non Marring Gripping Cam Assembly
SC-50NMST	Smooth Stainless Non Marring Gripping Cam Assembly
SC-52	Gripping Cam Spacers
SC-54	Gripping Cam Body Pin with (2) roll pins
SC-61	Lock Spring
SC-65	Lock Handle Assembly - includes Lock, Handle, Handle Spacer, (1) roll pin for handle & lock
SC-80	Connecting Yokes (pair) and spring connector pin

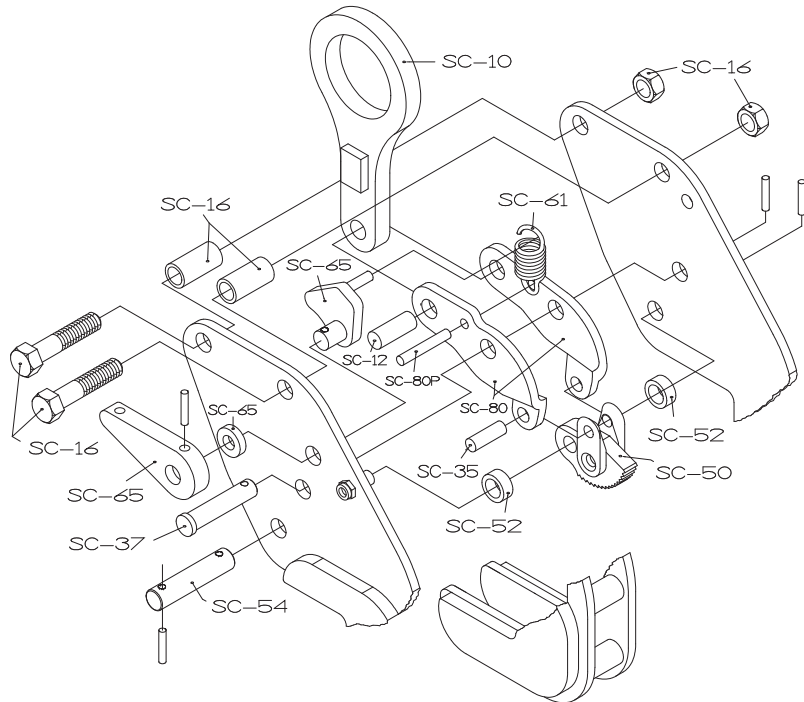

Figure 5

Part #	Parts List for 2 ton and up Model HBC
SC-10	Lifting Shackle
SC-12	Lifting Shackle Pin
SC-16	Body Bolt Assembly (1 spacer, bolt, & nut)
SC-35	Connecting Yoke-Cam Link Pin
SC-37	Connecting Yoke Body Pin with roll pin
SC-42	Gripping Cams (pair)
SC-42ST	Stainless Gripping Cams (pair)
SC-42NM	Smooth Steel Non Marring Gripping Cams (pair)
SC-42NMST	Smooth Stainless Non Marring Gripping Cams (pair)
SC-44	Gripping Cam-Link Pin
SC-54	Gripping Cam Body Pin with (2) roll pins
SC-61	Lock Spring
SC-65	Lock Handle Assembly - includes Lock, Lock Shim, Handle, Handle Spacer, (1) roll pin for handle & lock, (1) retainer roll pin for lock spring
SC-80	Connecting Yokes (pair) and spring connector pin

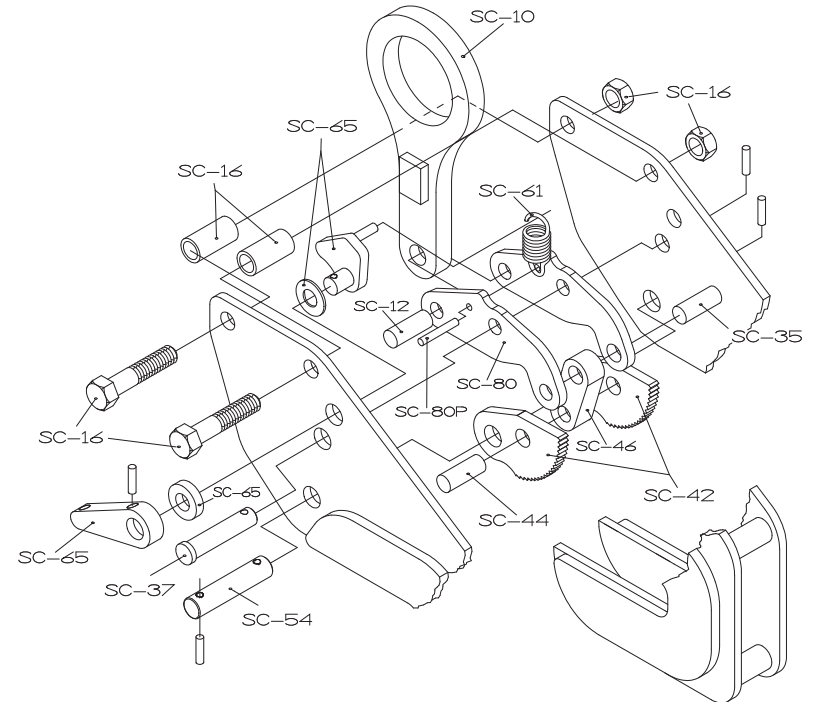

Figure 5

INSPECTION AND MAINTENANCE

The Safety Clamps Inspection and Maintenance schedule and procedures meet and/or exceed the requirements set forth in the ASME B30.20 Below-the-Hook Lifting Devices guideline. The severity of service the clamp is subjected to will determine the frequency and type of inspection required for the clamp and will be determined by the clamp owner.

Inspection Before and After Each Use

1. Before using any Safety Clamp, the operator must read and understand the Operator's Manual in its entirety.
2. All Safety Clamps should be inspected before and after each use. Do not use if any components are bent, elongated, gouged, nicked excessively, worn, and/or damaged. Make sure that nuts, bolts, pins, and other mechanical fasteners are tightened and secure.
3. Be sure the clamp to be used is the proper clamp for the job. Check the rated capacity and jaw opening stenciled on the Identification Tag. Both should equal or exceed the requirements for the load to be lifted.

Warning: Never exceed the rated capacity or use on material that is not within jaw range of the clamp.

4. Do not use the clamp if the Identification Tag or the Warning Tag is missing or illegible.
5. Inspect the gripping cam(s) (SC-50 or SC-42, Fig. 5) for wear and defects. Gripping surfaces must be sharp and free of foreign matter.
6. Inspect condition of body for wear, damage and distortion, particularly in the area of the jaw opening and holes for pins.
7. Inspect the lifting shackle (SC-10, Fig. 5) and all pins for wear and damage.
8. The lock spring (SC-61, Fig. 5) must have a definite amount of tension when the lock is moved to the Lock Closed position (Fig. 4), with minimal material in the clamp.
9. Remove from service and tag any clamp in need of repair indicating the problem area and bring to supervisor's attention. A full periodic inspection is to be performed at this time by qualified personnel. The next periodic inspection will be timed from when the clamp is returned to service.
10. Make sure that all roll pins are securely in place.
11. Never use a clamp in need of repair.

INSPECTION AND MAINTENANCE

Periodic Inspection

A periodic inspection is to be performed by qualified personnel. The inspection will be performed based on the level of service of the clamp:

Normal Service:	Annual Inspection
Heavy Service:	Semi-Annual Inspection
Severe Service:	Quarterly

1. **Verify and record the model, rated capacity, jaw opening, and serial number of the clamp which is stenciled on the Identification Tag.** If the tag is missing or not legible, the serial number is stamped into the body of the clamp. Contact Safety Clamps, Inc. and we will identify your clamp by the serial number and issue an RGA number to return the clamp to us. We will replace the Identification Tag at no charge.
2. **Completely disassemble the clamp.** Disassembly directions are on page 12.
3. **Remove all dirt, grease, and other foreign matter** that may inhibit proper inspection of the clamp body or clamp components.
4. **Clamp Body Inspection**
 - a.) Inspect all welds and all internal and external surfaces for fractures, wear, and distortion.
 - b.) Inspect all pin holes for wear and elongation.
 - c.) Inspect inside the jaw opening for displaced metal and distortion.
 - d.) Inspect the lock pivot holes for excessive wear.
5. **Lifting Shackle (SC-10, Fig. 5) Inspection**
 - a.) Inspect the lifting eye for elongation and wear at the point where the eye engages the sling attachment.
 - b.) Inspect the shackle pin hole for wear and elongation.
 - c.) Inspect the shackle body for bending.

Warning: Replace lifting clamps containing any fractures, elongated holes, jaw opening with displaced metal, and/or distorted jaw openings.

Warning: Replace shackles that are bent, show excessive wear, or have elongated eye or shackle pin holes.

INSPECTION AND MAINTENANCE

Periodic Inspection - cont'd

6. **Gripping Cam (SC-50 or SC-42, Fig. 5) Inspection**
- Inspect the gripping cam(s) for chipped or worn teeth. The teeth must be sharp and free of foreign matter.
 - Inspect pin holes for elongation and wear.
 - For the SC-50, inspect the connecting links for distortion and fractures. Inspect the pin holes for elongation and wear. Inspect the connecting pin for distortion, wear, and fractures. The gripping cam should pivot freely in assembly.

Warning: Replace cam assembly (SC-50) or gripping cams (SC-42) with worn or damaged teeth, that contain fractures, and cams and cam arms that have elongated pin holes.

7. **Gripping Cam Connecting Link (SC-46, Fig. 5) Inspection**
- Inspect pin holes for elongation and wear.
 - Inspect the gripping cam connecting link for distortion and fractures.

Warning: Replace gripping cam connecting link that is distorted, fractured, or if pin holes are worn or elongated.

8. **Shackle Pin (SC-12), Connecting Cam Pin (SC-35), Connecting Yoke Body Pin (SC-37), Gripping Cam Connecting Pin (SC-44), and Gripping Cam Body Pin (SC-54) Inspection (Refer to Fig. 5)**
- Inspect all pins for:
 - Distortion
 - Surface blemishes
 - Wear
 - Fractures

Warning: Replace pins that are distorted, have surface scars, are worn, or contain fractures.

9. **Connecting Yokes (SC-80, Fig. 5) Inspection**
- Inspect pin holes for elongation and wear.
 - Inspect the connecting yokes for distortion and fractures.
 - Inspect lock ear area where the lock engages for wear. If worn the clamp may not fully lock open with the gripping cam(s) (SC-50 or SC-42) out of the jaw area.

Warning: Replace connecting yokes that are distorted, fractured, if pin holes are elongated or worn, or if lock ear is worn.

INSPECTION AND MAINTENANCE

Periodic Inspection - cont'd

10. **Lock Spring (SC-61, Fig. 5) Inspection**
- Inspect the lock spring for distortion. The lock spring must have a definite amount of tension when the lock handle assembly is moved to the Lock Closed position (Fig. 4), with minimal material in the clamp.

Warning: Replace the lock spring if it is damaged, distorted, or lacking in spring tension.

11. **Lock Assembly (SC-65, Fig. 5) Inspection**
- Inspect the lock assembly for damage and wear. Inspect area that engages connecting yoke (SC-80) for wear or distortion. If worn the clamp may not fully lock open with gripping cam(s) out of the jaw.
 - Inspect the lock assembly for binding. The lock assembly should pivot freely. Binding indicates worn parts and/or foreign matter in the assembly.

Warning: Replace lock assembly if any parts are worn or damaged, fit loosely in the body hole, or do not have a definite "Locked Close" or "Locked Open" position.

12. **Body Bolt and Body Spacer (SC-16, Fig. 5) Inspection**
- Inspect the body bolts and body spacers for wear at the position where the body spacer contacts the lifting shackle (SC-10, Fig. 5).
 - Inspect the body bolts for wear or damage.
 - When replacing body bolt, tighten nut on bolt until the nut is securely against the clamp body & the body spacer cannot rotate.

Warning: Replace body bolt & nut and body spacer if worn or damaged.

13. **Clamp Assembly Inspection**
- After re-assembling the clamp, check the operation of the clamp. All parts should move freely without binding. Refer to the exploded view (Fig. 5) of the clamp for proper location of all component parts.

Warning: All retaining pins and fasteners must be in place.

14. **Maintenance Log Entry**
- After any work is performed on the clamp, the maintenance log book must be updated to show verification of these repairs. The log book will be kept and maintained by the company maintenance personnel.



SAFETY CLAMPS, INC.

HOME OF THE "BIG BITE" LIFTING CLAMP

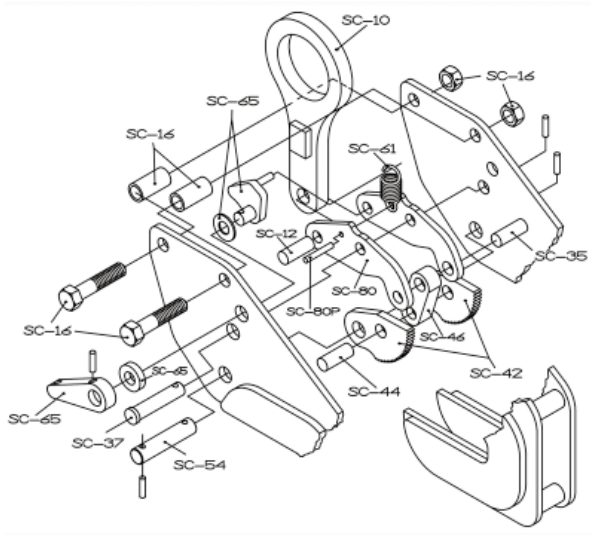

Register Your Clamp

Go to www.safetyclamps.com to register your clamp to receive the most appropriate service, product support, and training aids for your clamp and also receive updates on new products.

10 Year Limited Warranty

See inside front cover for details.

Call, Fax, or email Us Today!

Safety Clamps, Inc.

233 Santa Barbara Ave.

Jacksonville, FL 32254

www.safetyclamps.com

email: info@safetyclamps.com

Phone 904-781-2809

800-456-2809

Fax 904-786-2116

Effective January 1, 2016

This Manual is only for Model HBC clamps manufactured after 2015.

Contact Safety Clamps, Inc. to obtain a manual for a Model HBC clamp manufactured before 2016.